

# Mahlanlage Pharma Mill for pharmaceutical products

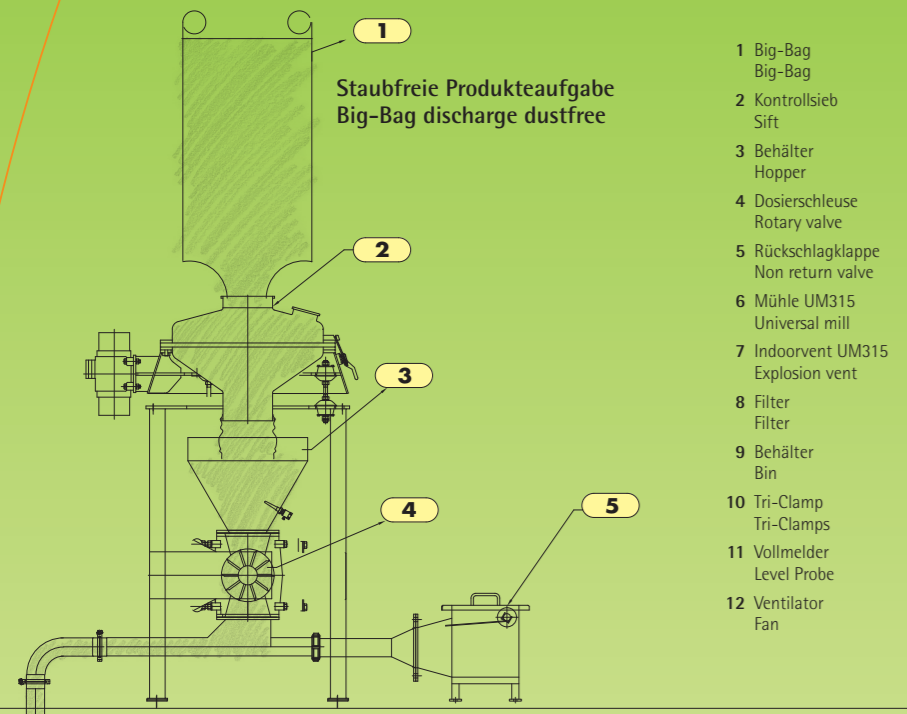

- 1 Big-Bag  
Big-Bag
- 2 Kontrollsieb  
Sift
- 3 Behälter  
Hopper
- 4 Dosierschleuse  
Rotary valve
- 5 Rückschlagklappe  
Non return valve
- 6 Mühle UM315  
Universal mill
- 7 Indoorvent UM315  
Explosion vent
- 8 Filter  
Filter
- 9 Behälter  
Bin
- 10 Tri-Clamp  
Tri-Clamps
- 11 Vollmelder  
Level Probe
- 12 Ventilator  
Fan

## Reinraum Clean room

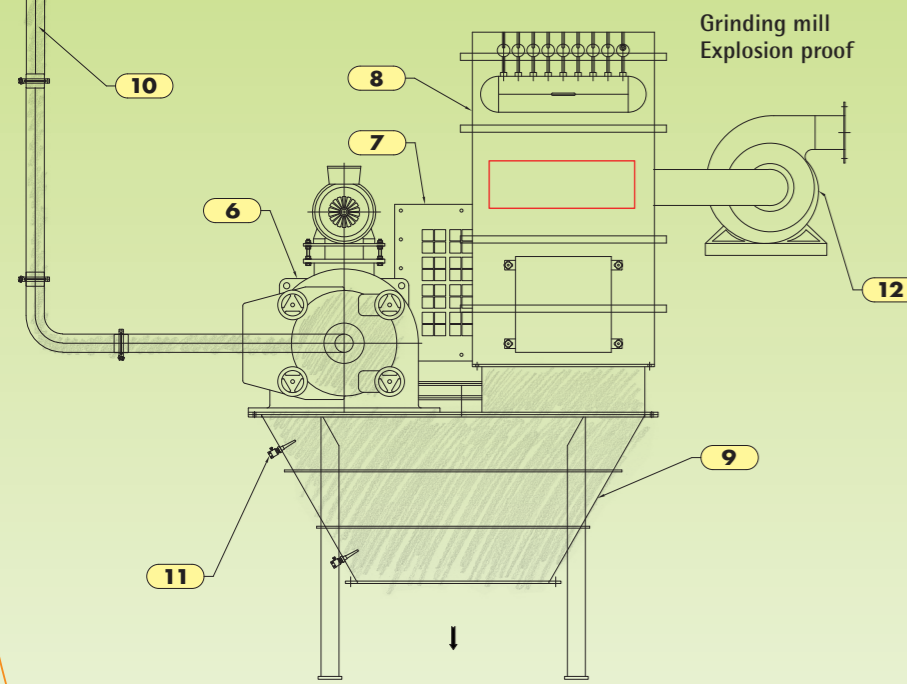

Particle Size Analyses  
Natriumbicarbonat

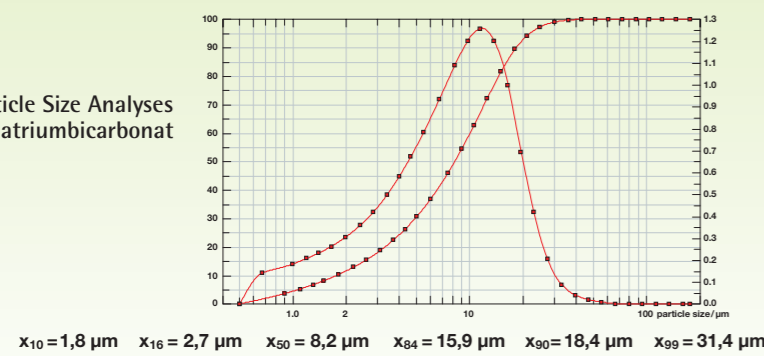

Anutec ist Spezialist in der mechanischen Verfahrenstechnik für Schüttgüter aller Art.

Wir haben die Fachkompetenz, über 40-jährige Erfahrung in der Herstellung von Maschinen für das Sieben, Mischen und Zerkleinern von Schüttgütern. Enge Zusammenarbeit mit unseren Partnerfirmen, Spezialisten in Ihrem Fach sowie Ingenieurschulen der Region sind die Garanten dass neueste Technologie zum Einsatz kommt.

Die Zerkleinerungsmaschinen, Mühlen, Siebe, Mischer sind meisten Herzstücke einer Produktionsanlage. Entsprechend der Wichtigkeit, sind die Maschinen robust und betriebssicher gebaut.

Unsere Kunden sind Hersteller von Lebensmittel, Chemie und Pharmaprodukten, Anlagenbauer und Ingenieurbüros.

Anutec provide the equipment, knowledge and skills required for the successful planning and implementation of tailor-made solutions for size reduction, milling, sifting and mixing in the field of Powder Processing.

The majority of Anutec's customers supply the Food, Chemical and Pharmaceutical industries and range from independent companies to OEM's and engineering consultants from all over the world. This loyal customer base provides the backbone for Anutec's business.

Anutec's range of machines include granulators, mills, sifters and mixers are manufactured at very high quality, being both solid and reliable as this machinery is often a key component in the production line. Standard machines are made to order and custom-built machines can be offered according to the customers needs.

# Lebensmittel - Chemie - Pharma Food - Chemical - Pharma



## Verarbeitung von Schüttgütern Powder processing and handling



Well equipped test room in Düringen



Grinding mill with filter for pharmaceutical, explosion proof, CIP



Sugar mill with filter and receptacle explosion proof



Inline sifter GSC900 in suction conveying in food branch



**anutec**  
Your competent partner  
in powder processing

Anutec GmbH  
Duensstrasse 5 | 3186 Düringen Switzerland | Phone +41 (0)26 493 04 24  
Fax +41 (0)26 493 04 25 | contact@anutec.ch | www.anutec.ch



**anutec**  
Your competent partner  
in powder processing